

Service Manual

Cordless Rotary Hammer

Model No. **EY7880**

North America

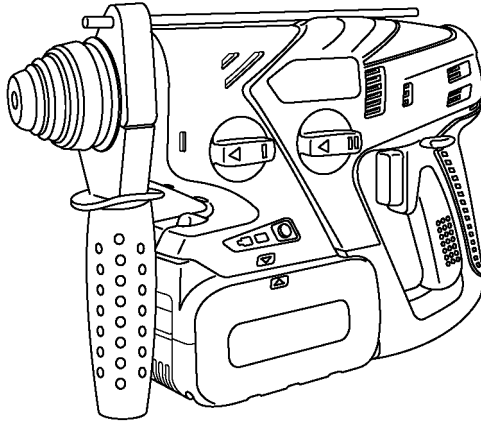

⚠ WARNING

This service information is designed for experienced repair technicians only and is not designed for use by the general public. It does not contain warnings or cautions to advise non-technical individuals of potential dangers in attempting to service a product. Products powered by electricity should be serviced or repaired only by experienced professional technicians. Any attempt to service or repair the product or products dealt with in this service information by anyone else could result in serious injury or death.

IMPORTANT SAFETY NOTICE

There are special components used in this equipment which are important for safety. These parts are marked by **⚠** in the Schematic Diagrams, Circuit Board Diagrams, Exploded Views and Replacement Parts List. It is essential that these critical parts should be replaced with manufacturer's specified parts to prevent shock, fire or other hazards. Do not modify the original design without permission of manufacturer.

TABLE OF CONTENTS

	PAGE	PAGE
1 Warning-----	2	
2 Specifications -----	2	
3 Troubleshooting Guide-----	3	
4 Disassembly and Assembly Instructions -----	7	
5 Wiring Connection Diagram -----	13	
6 Schematic Diagram-----	14	
7 Exploded View and Replacement Parts List -----	15	

1 Warning

Caution:

- Pb free solder has a higher melting point than standard solder; Typically the melting point is 50 - 70°F (30 - 40°C) higher. Please use a soldering iron with temperature control and adjust it to 750 ± 20°F (400 ± 10°C). In case of using high temperature soldering iron, please be careful not to heat too long.
- Pb free solder will tend to splash when heated too high (about 1100°F / 600°C).

2 Specifications

MAIN UNIT

Motor		28.8V DC
Speed at NO load	SLOW mode	0-500 min ⁻¹ (rpm)
	HIG mode	0-920 min ⁻¹ (rpm)
Blows rate per minute	SOFT mode	0-2800 min ⁻¹ (bpm)
	HARD mode	0-4500 min ⁻¹ (bpm)
Maximum drilling diameter	Concrete	20mm (25/32")
	Steel	13mm (33/64")
	Wood	27mm (1-1/16")
Blow strength	SOFT mode	12.7kN (1300kgf)
	HARD mode	23.6kN (2400kgf)
Overall length		319mm (12-9/16")
Weight (with battery pack EY9L40)		3.80kg (8.4lbs.)

3 Troubleshooting Guide

(Refer to WIRING CONNECTION DIAGRAM)

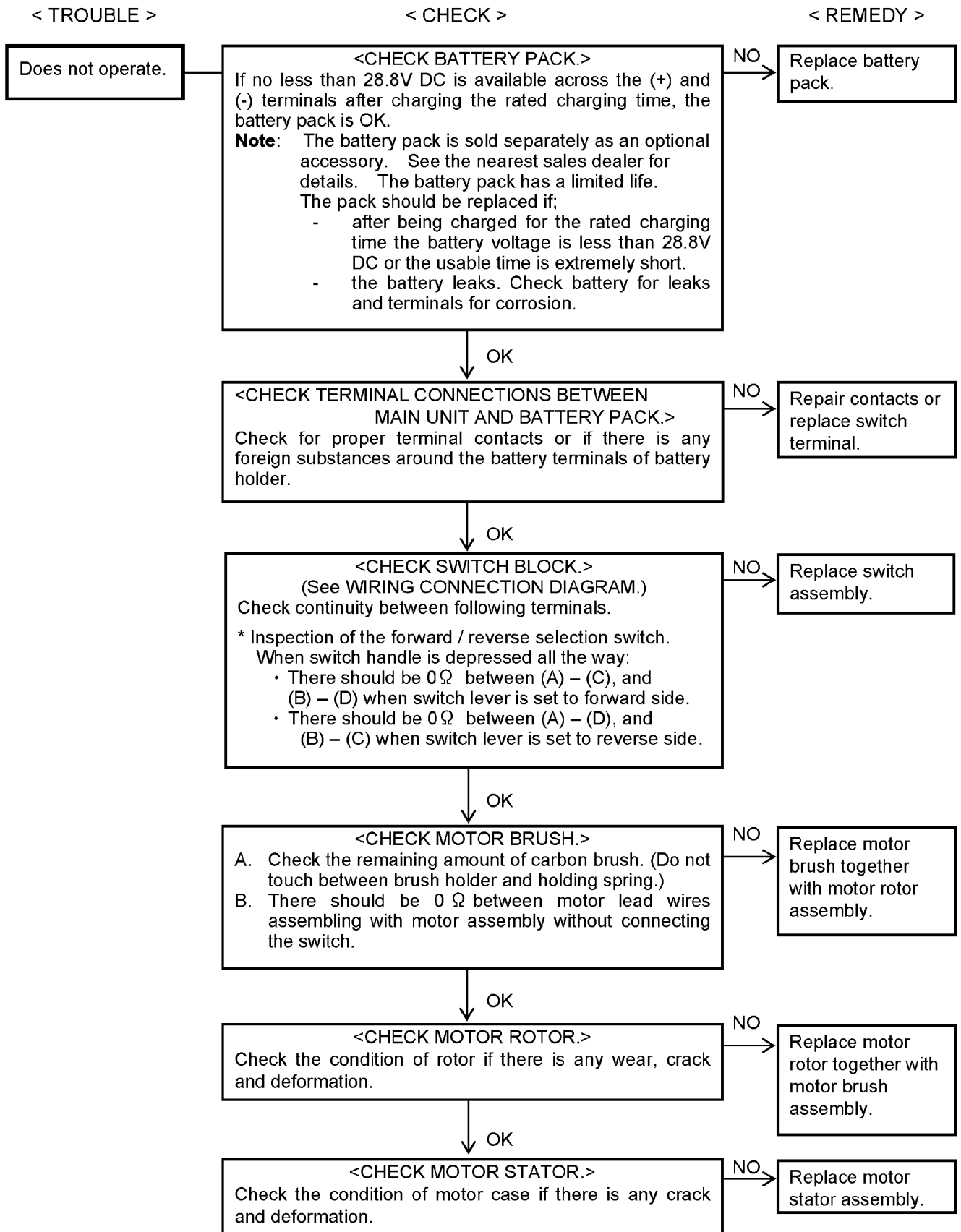

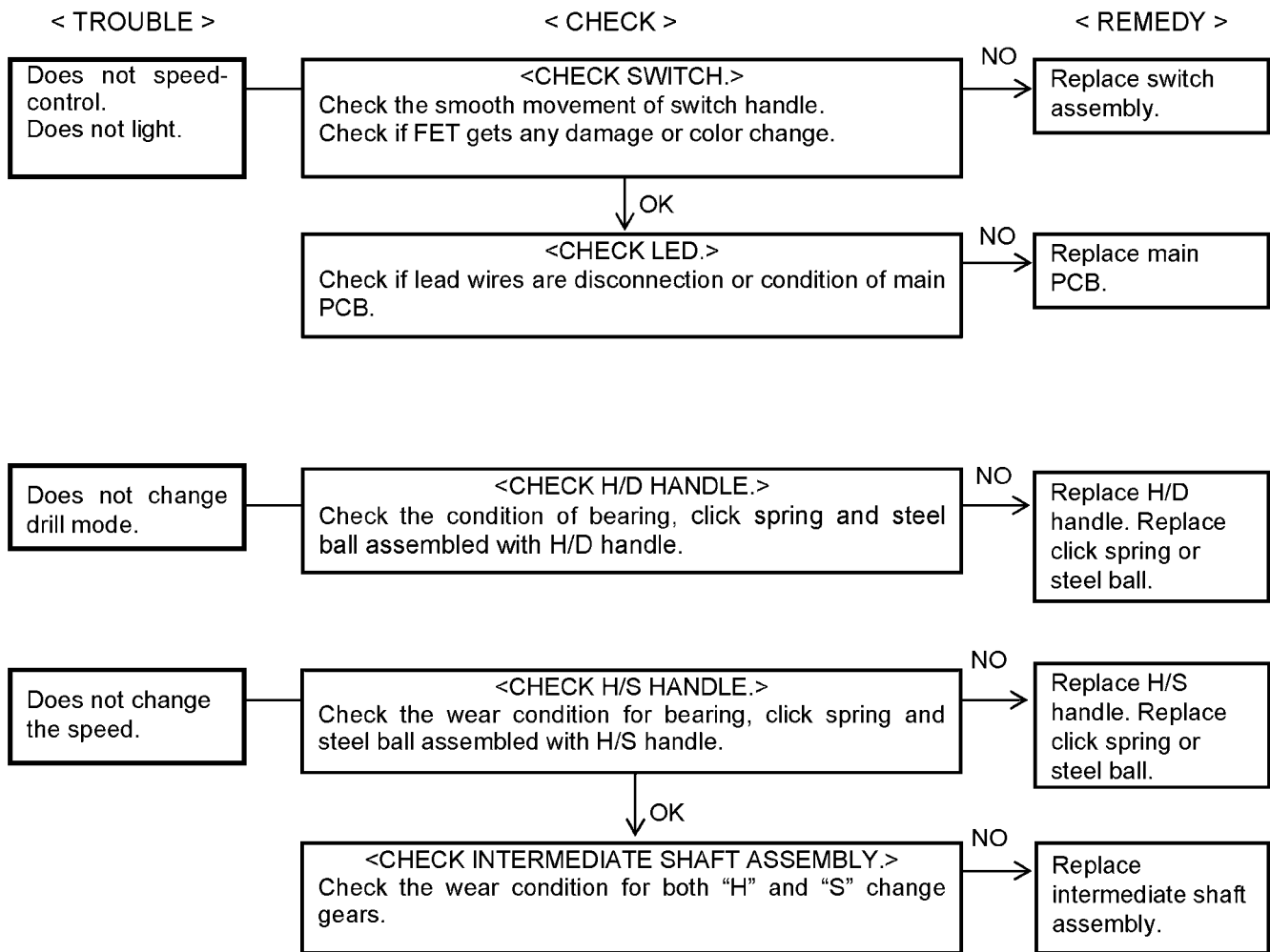

NOTE: Before starting the following procedure, check the battery pack and rotation speed of main unit. Confirm if it is 950rpm with HIGH and HAMMER mode by applying DC28.8V on the constant voltage source. If not, replace motor brush, rotor and stator all together.

< TROUBLE >

< CHECK >

< REMEDY >

Does not hammer or weakness of hammering.

<CHECK SPINDLE BLOCK.>
Check the wear condition of hammer O-ring and inside of cylinder and spindle.

NO → Replace cylinder, spindle and O-ring.

OK

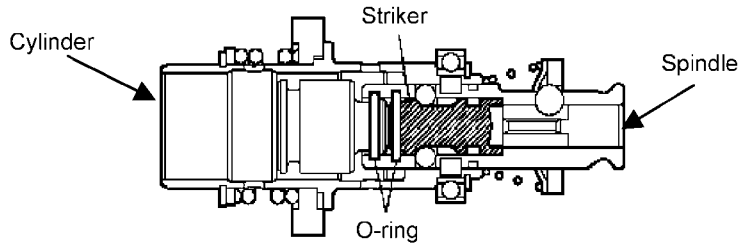

<CHECK INTERMEDIATE SHAFT ASSEMBLY.>
Check the wear condition of the change clutch, spring and reciprocation bearing.

NO → Replace intermediate shaft assembly.

OK

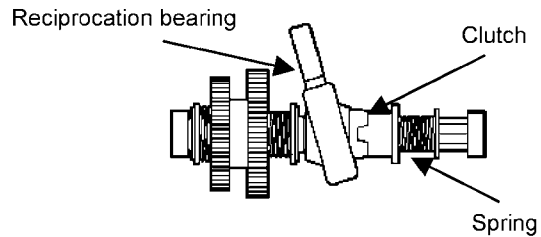

<CHECK STRIKER.>
Check the smooth action of striker.

NO → Replace Spindle assembly.

OK

<CHECK HAMMER BLOCK.>
Check the wear condition of inside of hammer O-ring.

NO → Replace hammer O-ring and greasing.

OK

<CHECK PISTON AND HAMMER BLOCK.>
Check the smooth action between reciprocation bearing and universal coupling. Check if the holes are not clogged.

NO → Replace piston or universal coupling.

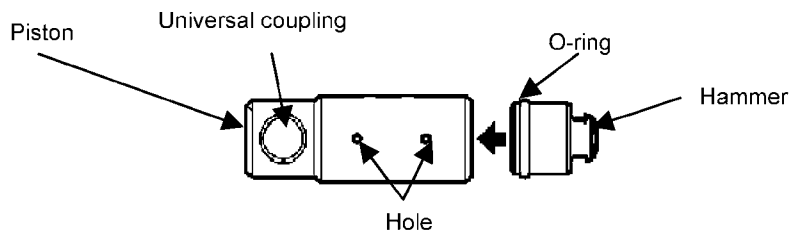

3.1. Trial Operation (After Checking Troubleshooting Guide.)

1. HAMMER/DRILL

Confirm the action when setting the H/D handle to HAMMER mode.

Rotation with hammering may work when the drill bit touches something like concrete or hard type of wood block. And confirm the power.

It is OK, if it takes about 4-6 seconds by 20kgf to hole ($\Phi 6 \times 30$) on the concrete

2. SWITCH

Change the rotation speed in proportion to the amount of pushing level on switch trigger.

HIGH: 0 -920 rpm LOW: 0 -500 rpm

3. CONTROL PCB

Check if the LED is lit.

Check if the Battery low warning lamp and Overheat warning lamp is lit.

4. ASSEMBLY



Confirm if there is NO gap between Housing A and B by pinching the lead wires.

Confirm all screws are tightened firmly and gaskets are attached.

There should be no metallic sound and abnormal sound.

4 Disassembly and Assembly Instructions

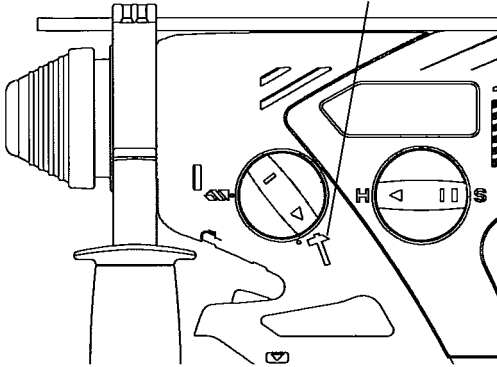
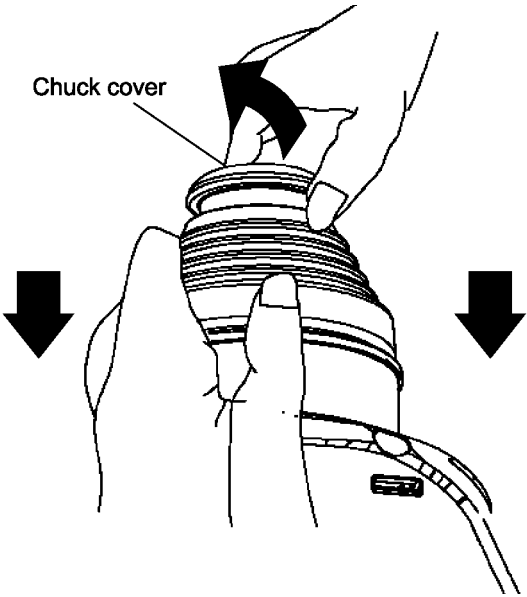
4.1. How to Disassemble the Main Unit.

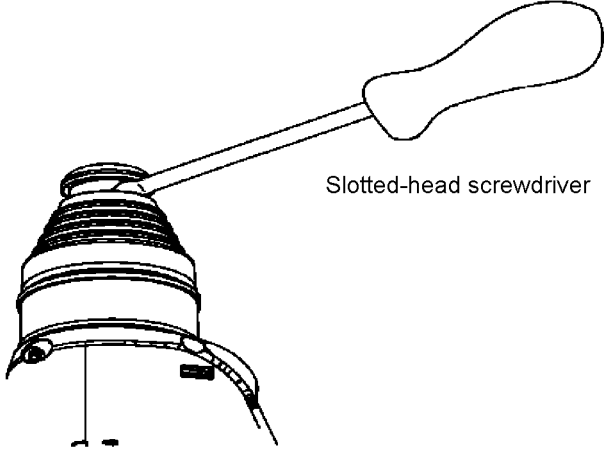
Ref. No. 1A	Procedure 1A	Removal of the chuck handle.
<p data-bbox="496 327 759 356">Set the HAMMER mode.</p>   <p data-bbox="197 831 336 860">Chuck cover</p>		<ol data-bbox="858 327 1469 405" style="list-style-type: none"> 1. Set the hammering/drilling switching lever to the position . 2. Loosen the support handle and take it out from the unit. 3. Pluck the chuck cover depressing the chuck handle. <p data-bbox="858 409 935 432">NOTE:</p> <p data-bbox="890 434 1445 456">If it is hardly to take out, use the slotted-head screwdriver.</p> <ol data-bbox="858 461 1461 566" style="list-style-type: none"> 4. Remove the chuck handle. 5. Take out a steel ball pushing the chuck spring with the chuck spring plate. 6. Remove the chuck spring plate and the chuck spring.  <p data-bbox="1219 994 1490 1016">Slotted-head screwdriver</p>

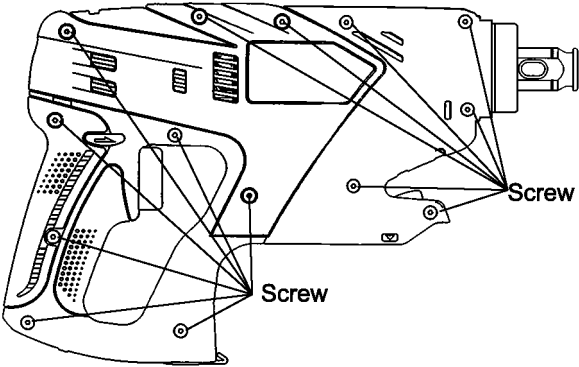
Ref. No. 1B	Procedure 1A → 1B	Removal of the housing.
 <p data-bbox="703 1682 772 1704">Screw</p> <p data-bbox="456 1783 525 1805">Screw</p>		<ol data-bbox="863 1471 1158 1494" style="list-style-type: none"> 1. Remove 14 housing screws.

Ref. No. 1C

Procedure 1A → 1B → 1C

Removal of the switch.

1. Loosen two screws to remove the lead wires from motor assembly.

NOTE:

- Do not lose the nut.
- Take out the switch from the housing.
- Take out the LED cover.

For assembling

NOTE:

Do not push the area where marked the arrow in order to prevent the breakage.

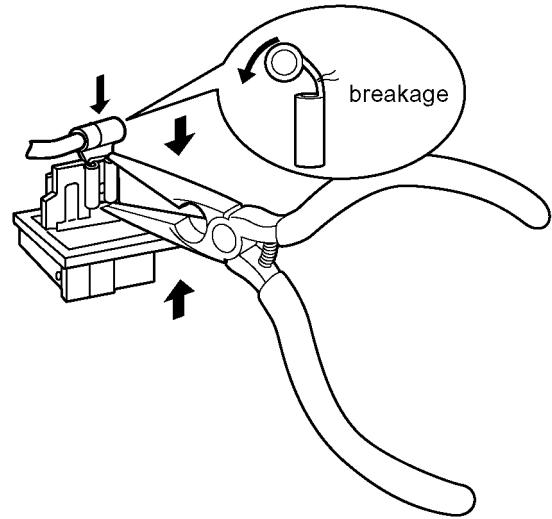
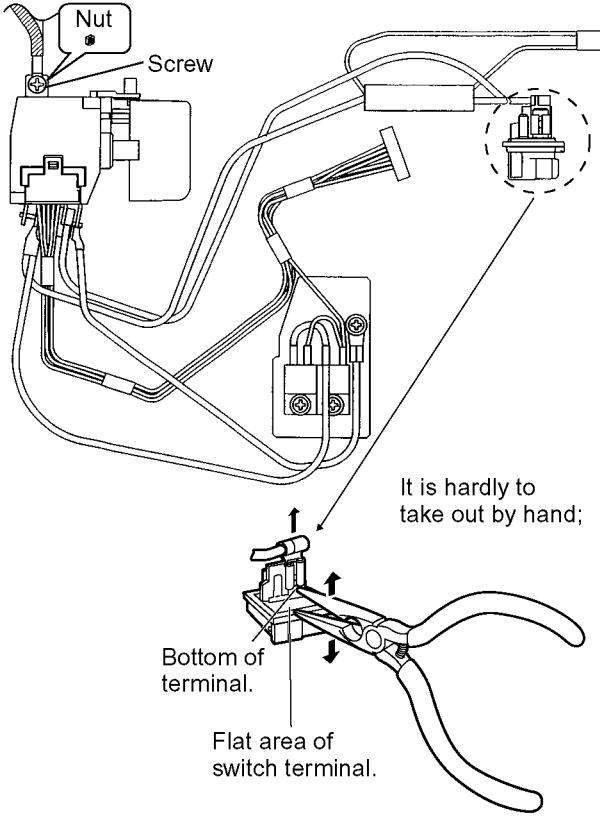

Ref. No. 1D

Procedure 1A → 1B → 1C → 1D

Removal of the motor assembly.

- Hitch the brush spring to the frame by something like a forceps and take the motor brush assembly with the switch out from the motor assembly.
- Take out the rotor and the current plate from the motor case.

For assembling

NOTE:

Make sure to return the spring into the groove of the motor brush. Make sure to set the motor case faced the printing side up. Close the housing and try to apply the DC28.8V and check if the motor rotates or not.

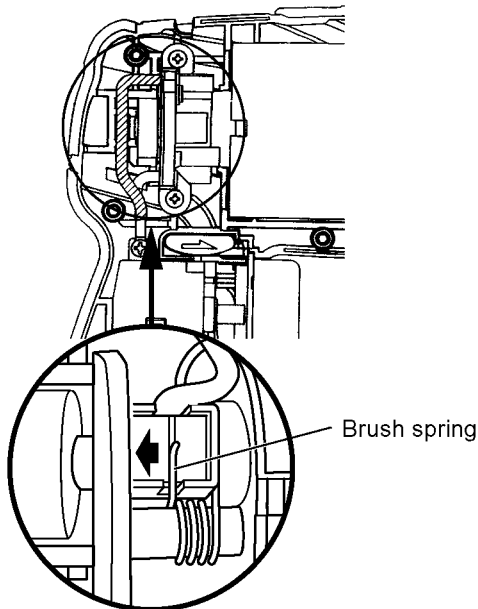

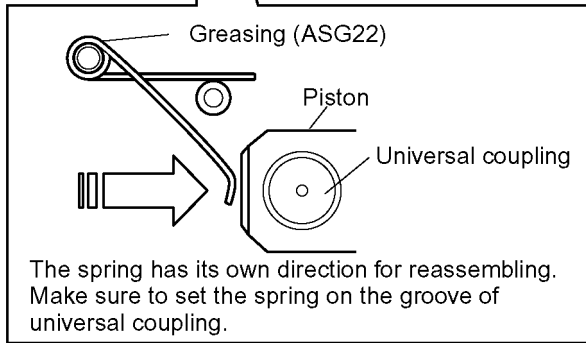
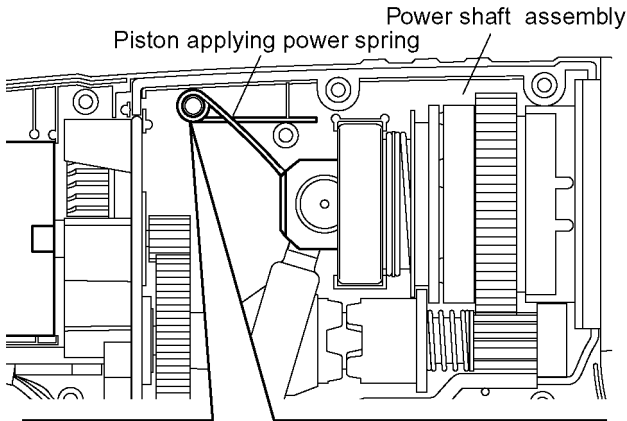

1. Remove the piston applying power spring.
2. Take out the power shaft assembly.
3. Remove the snap ring.
4. Slide the jig (plate) into between the washer and the gear case and hold it by a vise.
5. Tap the top of spindle block with a plastic hammer to take out the spindle and clutch block assembly.
6. Take out the snap ring on the rear side of the bearing.
7. Take out two pins by using absorption force about 30N magnet from the clutch block.
8. Take out four steel balls and remove the spindle & piston assembly.
9. Remove the striker with the O-ring and the O-ring. And take out the bearing.
10. Take out the piston block. And take out the piston and the universal coupling.
11. Remove the intermediate shaft assembly.

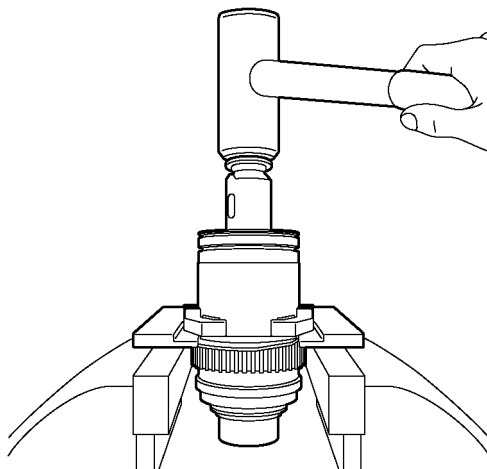
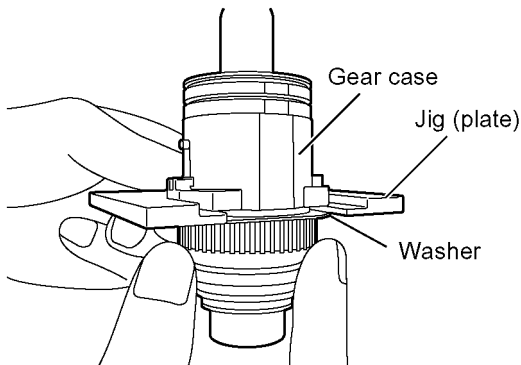

4.2. How to Reassemble the Main Unit.

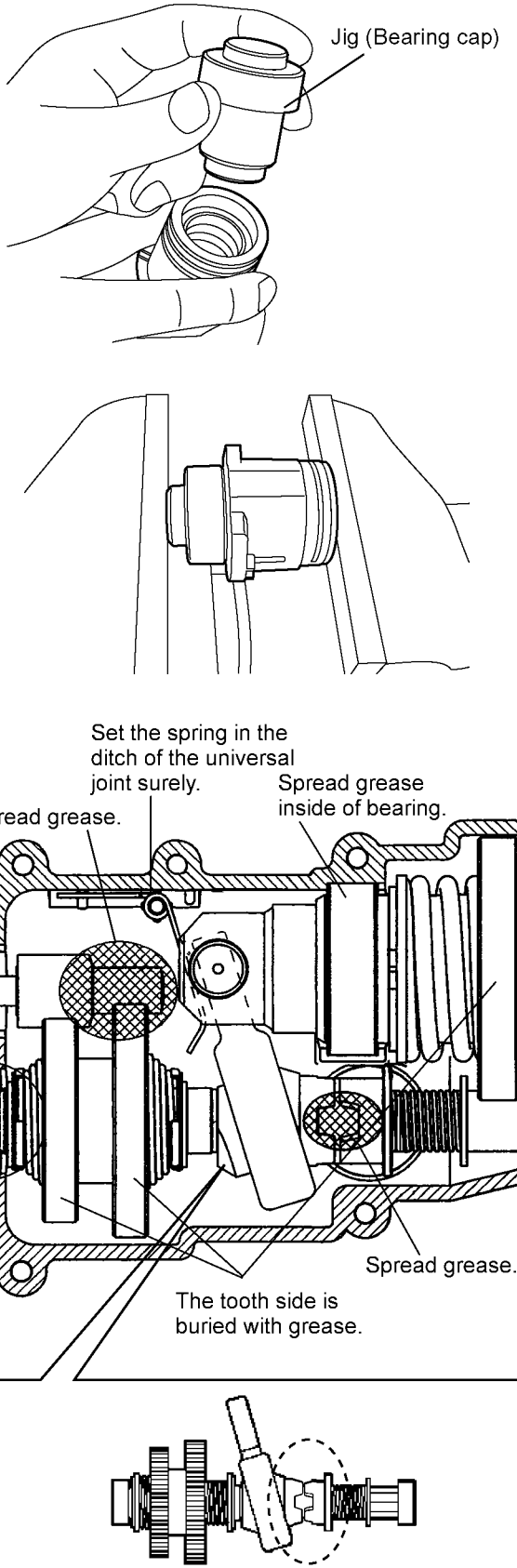
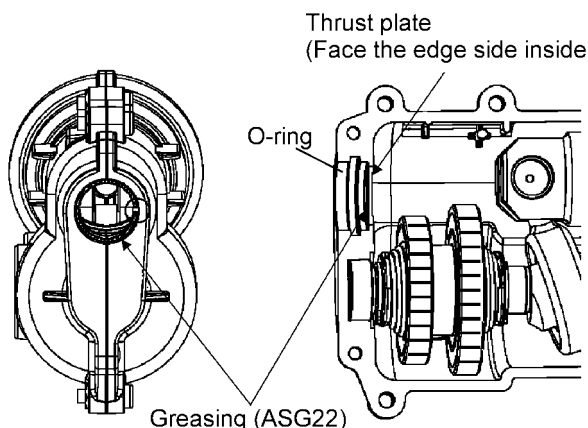
Ref. No. 2A	Procedure 2A	Assembly of gear case assembly.
	 <p>Jig (Bearing cap)</p> <p>Set the spring in the ditch of the universal joint surely.</p> <p>Spread grease.</p> <p>Spread grease inside of bearing.</p> <p>Spread grease.</p> <p>The tooth side is buried with grease.</p>	<p>Assembly of gear case assembly.</p> <ol style="list-style-type: none"> 1. Set the jig (bearing cap) into the clutch case and hold it with a vise in order to take out the bearing. 2. Assemble the bearing with the spindle assembly. 3. Set the snap ring. <p>NOTE: It has own direction for reassembly. Place the rounded face of snap ring to the clutch case side.</p> <ol style="list-style-type: none"> 4. Fit O-ring onto the bearing. 5. Place the thrust plate on the end of intermediate shaft assembly. 6. Insert the reciprocation bearing shaft into the hole of universal coupling. Make sure two thrust plates should be set both side of reciprocation bearing shaft one of each. 7. Assemble the intermediate shaft assembly into the gear case from the motor side first. <p>NOTE: Apply grease especially for the connection area between reciprocation bearing and universal coupling. In addition, hammer O-ring, inside of piston and cylinder for output shaft block also need to apply. Air compressed by the piston drives hammer. Take care to protect the piston and hammer from contamination by dust.</p>  <p>Thrust plate (Face the edge side inside.)</p> <p>O-ring</p> <p>Greasing (ASG22)</p>

Ref. No. 2B

Procedure 2A → 2B

Assembly of gear case assembly.

Spread an adhesive.

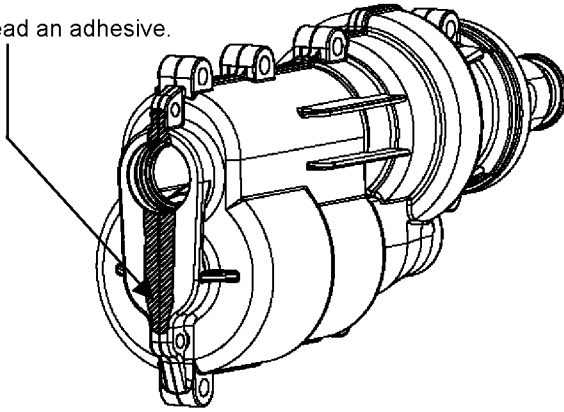

1. Assemble the chuck spring and the chuck spring plate.
2. Insert a ball pushing down the chuck spring.
3. Inject an adhesive such as Cemedine SX720WH and wipe off to bury the gap between the gear case A and B in order to prevent the leakage of grease inside of gear box.

NOTE:

Make sure an adhesive is completely dried before assembling the driving block into the housing.

Assembly of driving block into housing.

1. Set the H/D handle to HAMMER mode.
2. Set the H/S handle in between HIGH and SOFT model.
3. Insert the gear case assembly into the housing.
4. Connect the switch assembly with motor lead wires.

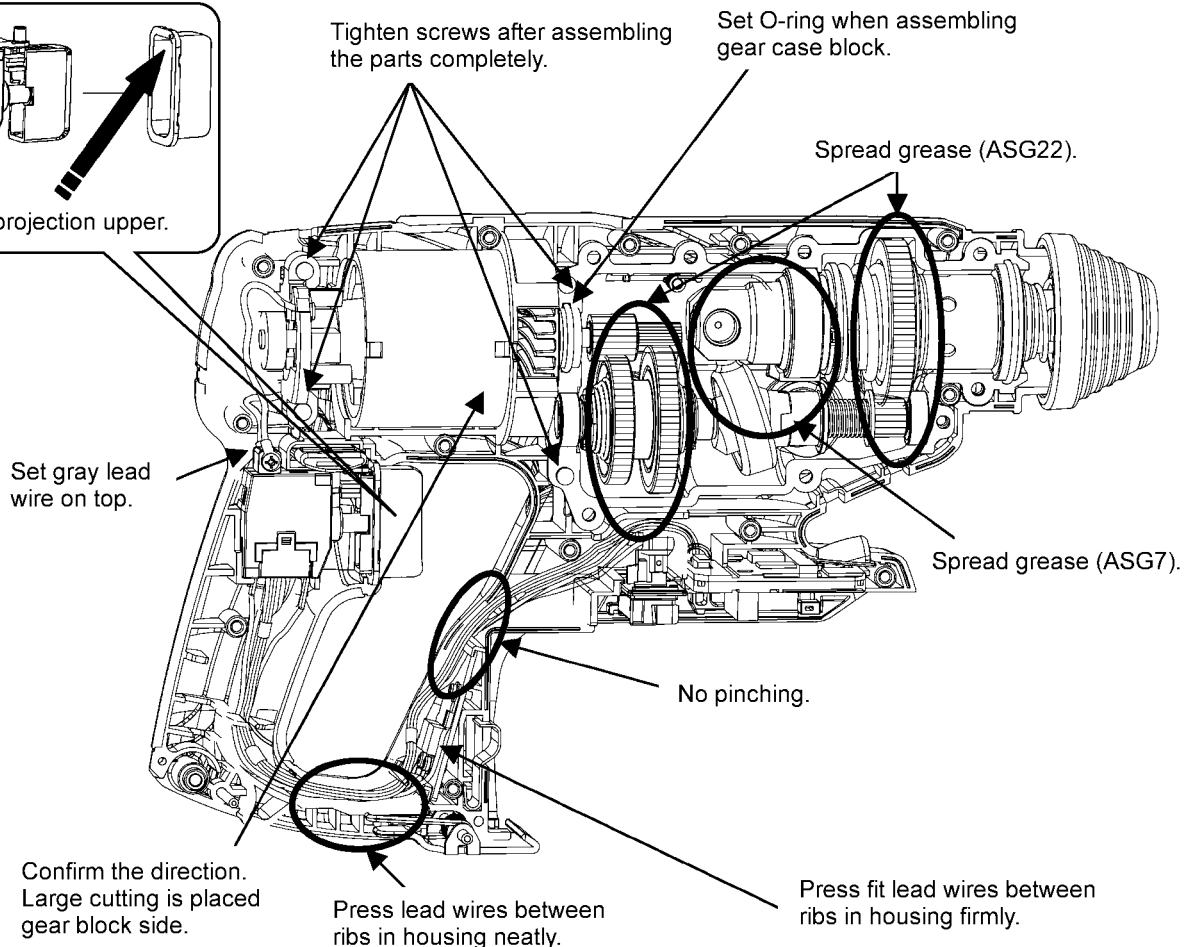
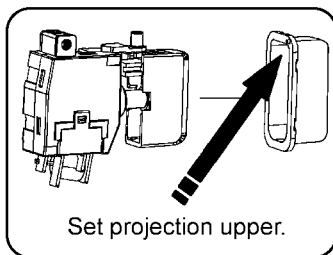
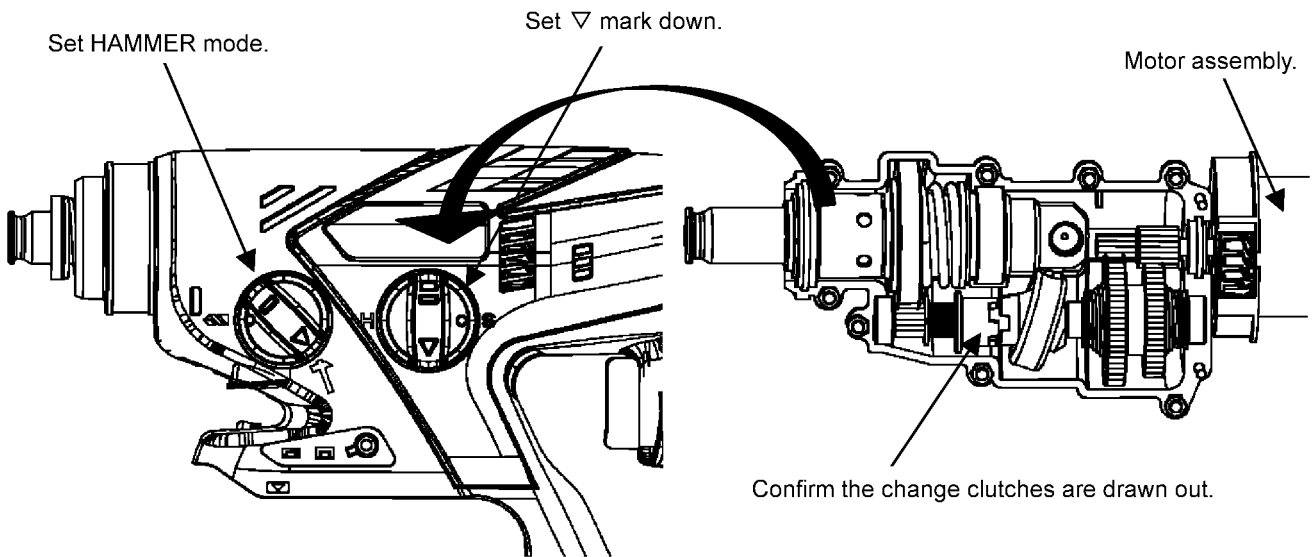

5 Wiring Connection Diagram

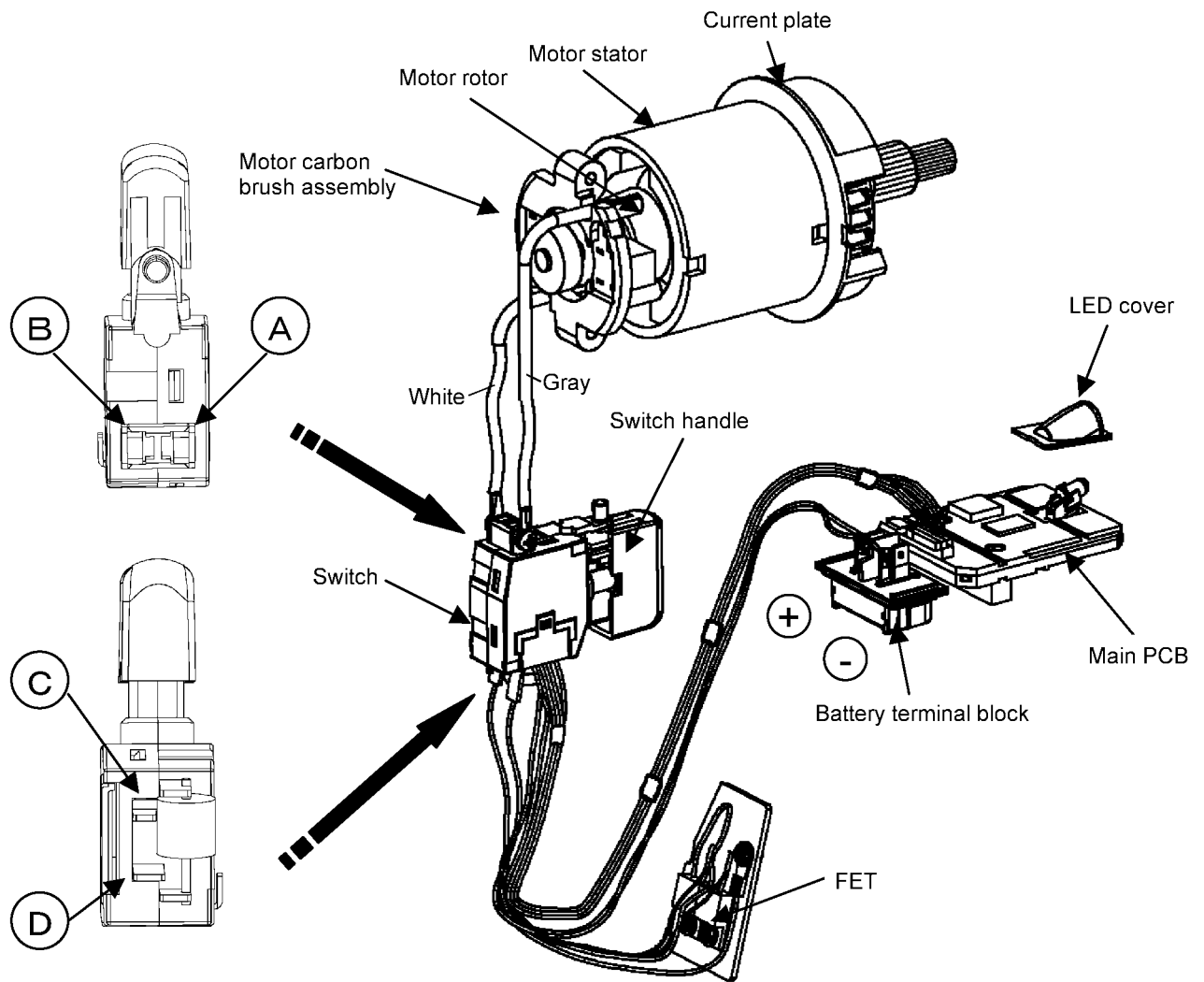

6 Schematic Diagram

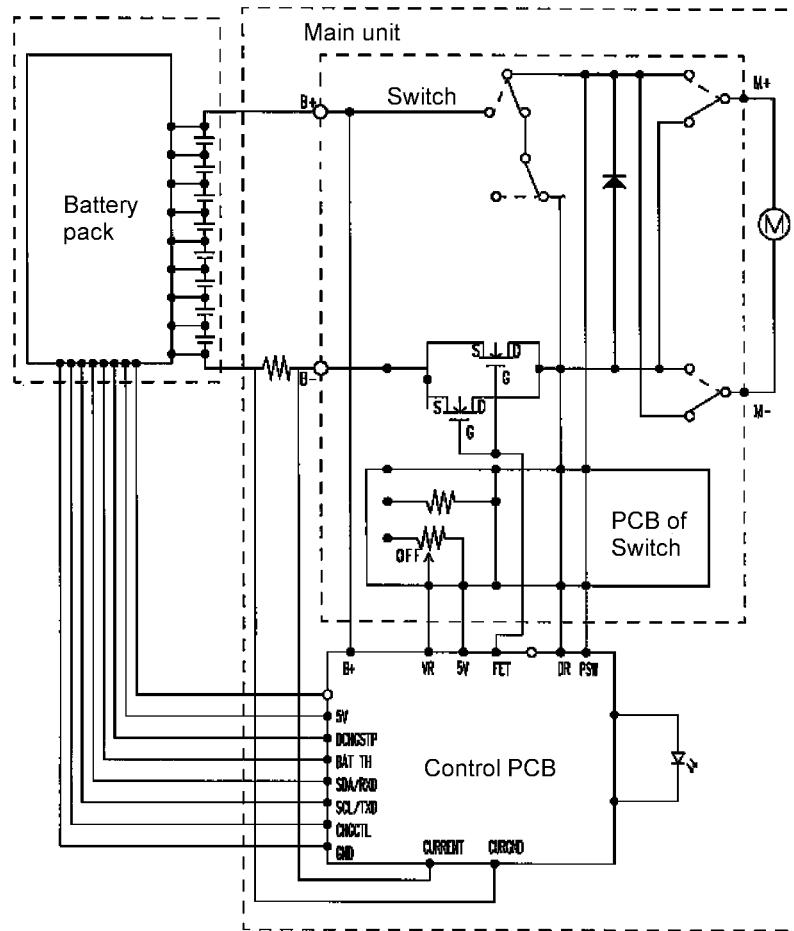

7 Exploded View and Replacement Parts List

Model No. : EY7880 Exploded View for EY7880

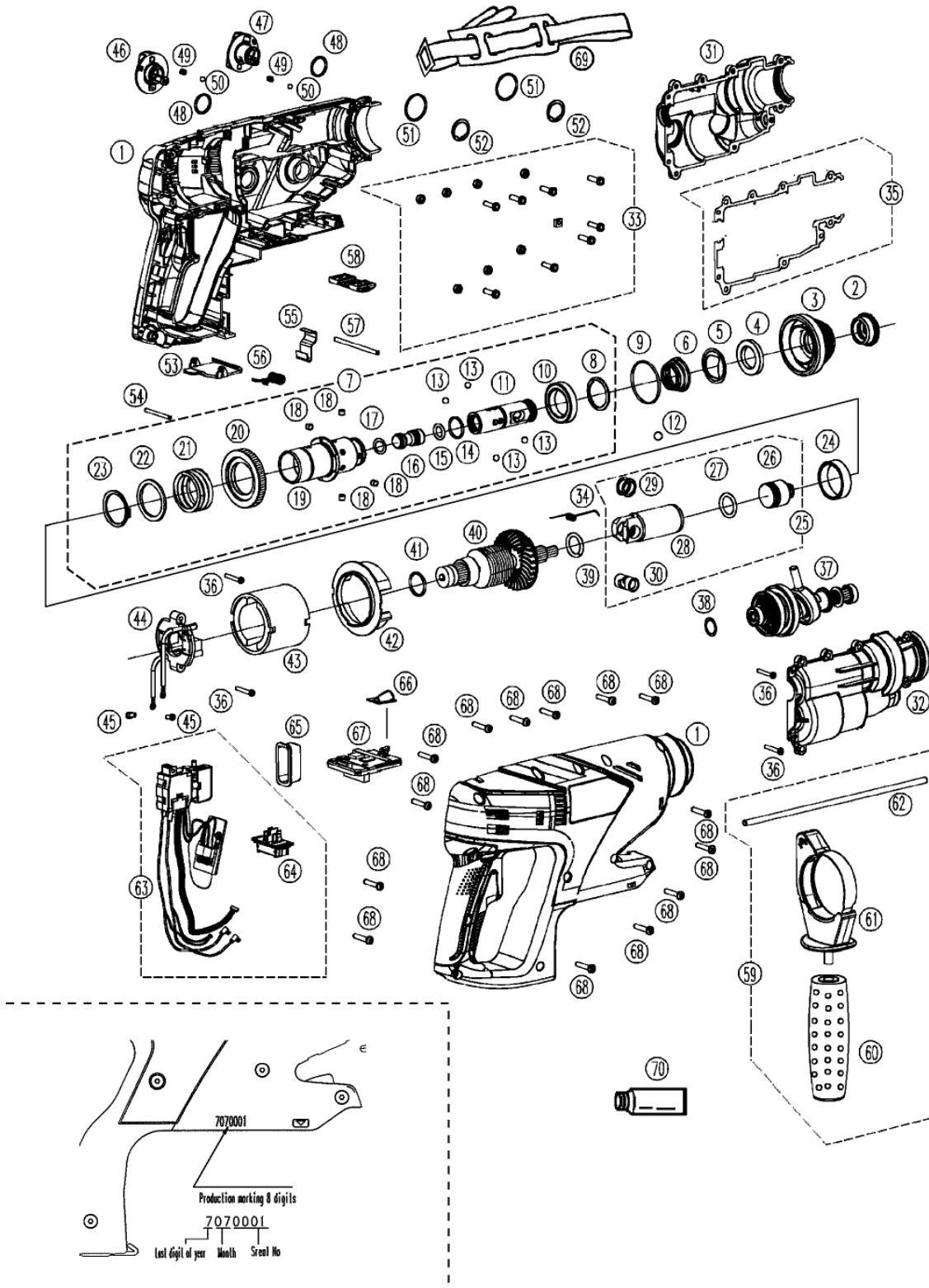

Model No. : EY7880 Parts List

Safety	Ref. No.	Part No.	Part Name & Description	Q'ty	Remarks
	1	WEY7880K3078	HOUSING AB SET	1	
	2	WEY6813H3116	CHUCK COVER	1	
	3	WEY6813K3126	CHUCK HANDLE	1	
	4	WEY6813L0426	BALL GUIDE	1	
	5	WEY6813L0436	CHUCK SPRING STRIKE PLATE	1	
	6	WEY6813L0916	CHUCK SPRING	1	
	7	WEY7880L4307	SPINDLE ASSEMBLY	1	
	8	WEY6813L0477	SNAP RING	1	
	9	WEY6813L0366	O RING	1	(ϕ 35)
	10	WEY6813L4957	BEARING	1	
	11	WEY7880L0057	SPINDLE	1	
	12	WEY6813L1916	STEEL BALL	1	(ϕ 7)
	13	WEY6813L1926	STEEL BALL	4	(ϕ 5), (4PCS/PK)
	14	WEY6813L0317	O RING	1	
	15	WEY6813L0327	O RING	1	
	16	WEY6813L1237	STRIKER	1	
	17	WEY7880L0337	O RING	1	(ϕ 3.2)
	18	WEY6813L0907	PIN	4	(ϕ 5 \times 4), (4PCS/PK)
	19	WEY6813L0067	CYLINDER	1	
	20	WEY6813L1397	POWER GEAR	1	
	21	WEY6813L0927	CLUTCH SPRING	1	
	22	WEY6813L0207	THRUST PLATE	1	
	23	WEY6813L0217	SNAP RING	1	(ϕ 30)
	24	WEY6812L0386	BEARING	1	
	25	WEY7880L1247	PISTON ASSEMBLY	1	
	26	WEY7880L4627	HAMMER	1	
	27	WEY6812L0976	O RING	1	
	28	WEY7880L1987	PISTON	1	
	29	WEY6812L0846	THRUST PLATE	2	(2PCS/PK)
	30	WEY7880L1257	UNIVERSAL COUPLING	1	
	31	WEY7880L0017	GEAR CASE A	1	
	32	WEY7880L0027	GEAR CASE B	1	
	33	WEY7880L0897	SCREW AND NUT SET	1SET	
	34	WEY7880L0177	SPRING	1	(ϕ 3.5)
	35	WEY7880L0987	GASKET AB SET	1	
	36	WEY6930K9037	SCREW	4	(K3-20)
	37	WEY6813L4076	INTERMEDIATE SHAFT ASSEMBLY	1	
	38	WEY6502L0857	THRUST PLATE	1	
	39	WEY7880L0857	C-TYPE THRUST PLATE	1	
	40	WEY7880L1467	MOTOR ROTOR ASSEMBLY	1	
	41	WEY6813L0356	O RING	1	
	42	WEY6813L0446	CURRENT PLATE	1	
	43	WEY7880L4987	MOTOR CASE ASSEMBLY	1	

Model No. : EY7880 Parts List

Safety	Ref. No.	Part No.	Part Name & Description	Q'ty	Remarks
	44	WEY7880L4637	MOTOR BRUSH ASSEMBLY	1	
	45	WEY6261B6026	SCREW	2	(K3-6)
	46	WEY7880H4617	H/S HANDLE	1	
	47	WEY7880H4607	H/D HANDLE	1	
	48	WEY7880L0387	O RING	2	(φ15.6)
	49	WEY6813L1406	CLICK SPRING	2	(2PCS/PK)
	50	WEY7880B6967	STEEL BALL	2	(φ4)
	51	WEY7880L0377	O RING	2	
	52	WEY6813L0456	SNAP RING	2	(2PCS/PK)
	53	WEY7880L0257	LOCK LEVER	1	
	54	WEY7880L0507	PIN	1	(3*34)
	55	WEY7880L0167	PLATE SPRING	1	
	56	WEY7880L0187	SPRING	1	(φ4.8)
	57	WEY7880L0287	PIN	1	(3.5-60)
	58	WEY7880L3147	F/R HANDLE	1	
	59	WEY6813K4626	AUXILIARY HANDLE	1	
	60	WEY6813H3927	GRIP	1	
	61	WEY6813K4636	SUPPORT HANDLE	1	
	62	WEY6813H7726	DEPTH GAUGE	1	
	63	WEY7880L4157	SWITCH ASSEMBLY	1	
	64	WEY7880L2157	BATTERY TERMINAL BASE	1	
	65	WEY7880L3137	TRIGGER COVER	1	
	66	WEY7880L3957	LED COVER	1	
	67	WEY7880L2117	MAIN PCB ASSEMBLY	1	
	68	WEY3503K6206	TORX TAPPING SCREW	14	(K4-20)
	69	WEY7880L3417	SHOULDER STRAP	1	
	70	WEY6812T7916	BIT GREASE	1	[SH]
	-	WEY9635K7018	TOOL CASE	1	[SH]
	-	WEY7880K8108	OPERATING INSTRUCTIONS	1	[SH]